



GAS DRYER TYPE GTR

www.hl-hydraulik.de

**For high pressure air and
non aggressive Medium for:**

- drying
- de-oiling
- filtering

- Benefits

- less corrosion
- less wear
- no icing

and consequently

- longer service life
- lower maintenance costs
- fail-safe operation

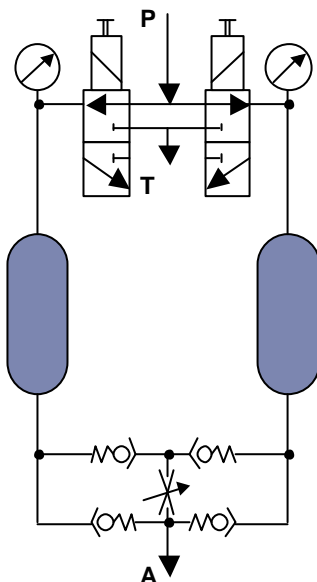

Ordering example: **GTR 10 24GL 250**

Operating pressure 30-250 bar Type 250
251-350 bar Type 350

Voltage: 24GL = 24VGL
220W = 220V50Hz

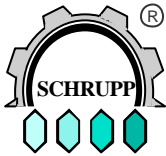

**GAS DRYER
TYPE GTR**

www.hl-hydraulik.de

Technical Data

Operating Pressure	30 - 350 bar
Flow Rate	1000 L/min
Regeneration Air	5-10% of Compressor
Volume of Reservoir	0,7 cdm
Max. Temperature	40°C
Relative Humidity	100%
Voltage	24GL, 220W
Power Consumption	35W
Baseplate Material	Brass / stainless steel
Mounting Plate Material	Brass / stainless steel
Reservoirs Material	Steel Chem. Nickel Plates
A and P Ports	G 3/8"
Weight	44 Kg

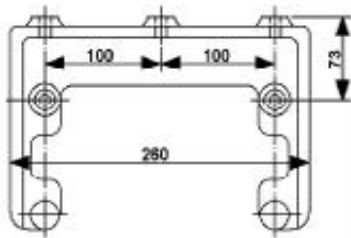
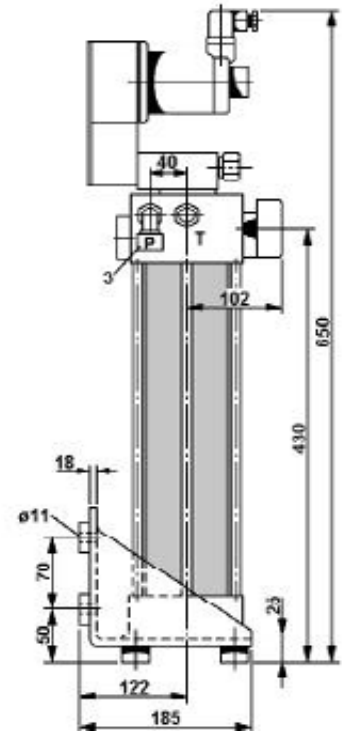
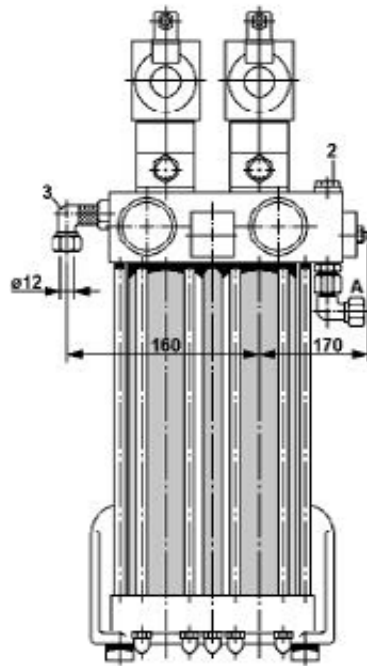

Part code Bracket
GTR K 507335

Part code program control unit
GTR PS 24GL (or 220W)

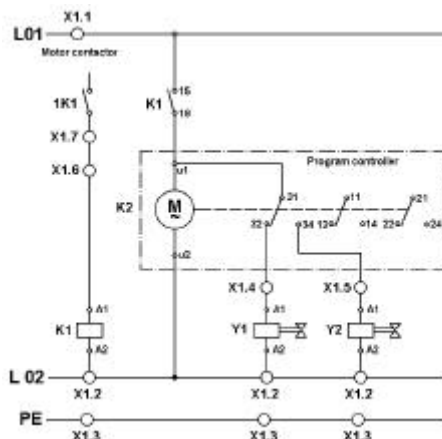
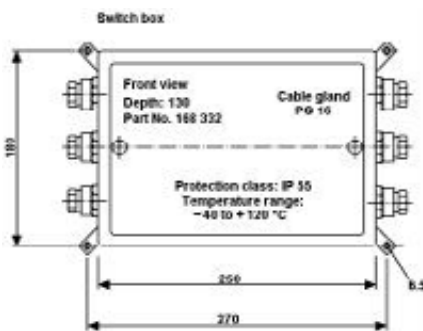

Destination Symbol	Terminal Strip	Destination symbol
Designation	Conn. No.	Designation
1K1	7	.
Y3	A1	K1
Y2	A1	34
Y1	A1	32
PE	3	.
Y2	PE	Y3
Y1	PE	.
Y2	A2	.
Y1	A2	Y3
L02	2	K1
L01	1	15

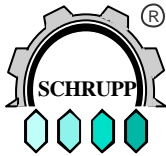

**GAS DRYER
TYPE GTF**

www.hl-hydraulik.de

**For compressed air and non aggressive gaseous media
drying de-oiling filtering**

this means
less corrosion less wear and no icing during operation
and therefore
greater service life lower maintenance costs

The gasdrier consists of two reservoirs filled with highly porous hydrostatic materials (adsorbents), into which damp compressed air and dried depressurized air are alternately admitted for the regeneration phase. The inlet and outlet of the adsorbent reservoirs are each fitted with a sintered metal disk to filter the water and oil particles out and also any particles from the adsorbate material.

Because of the modular design it is possible to flange up to three units together. The Basic unit includes all necessary directional, throttle and check valve functions. The second and third units include the additional adsorbent reservoirs to increase the capacity of the system.



Technical Data:

Operating pressure	40 – 350bar
Regeneration air consumption appr.	5%
Flow rate per unit	1300 l/min

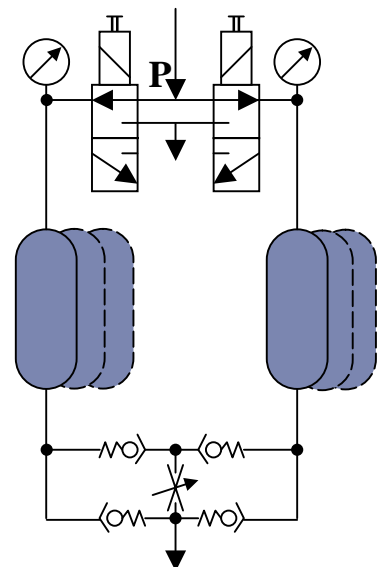
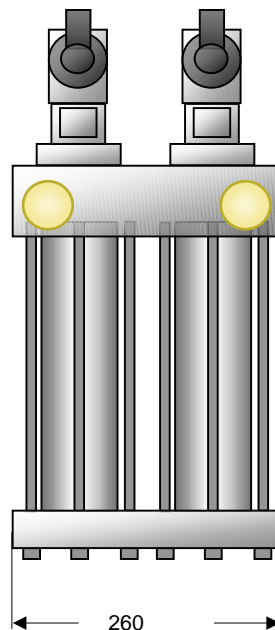
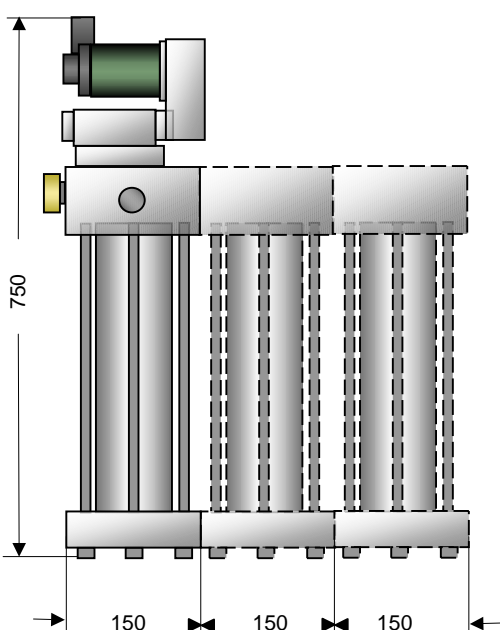



**GAS DRYER
TYPE GTR**

www.hl-hydraulik.de

SCHRUPP DRIER STATIONS

For

- drying
 - de-oiling
 - filtering
- compressed air and non-aggressive gaseous media**

This means

- less corrosion
 - less wear and
 - no icing
- during operation**

and therefore

- greater service life
- lower maintenance costs and
- fail safe operation





**GAS DRYER
TYPE GTR**

www.hl-hydraulik.de

SCHRUPP GAS DRYER STATIONS

Optional with Bypass

**For compressed Air and other
non aggressive gaseous media:**

- drying
- de-oiling
- filtering

this means

- less corrosion
- less wear and
- no icing
- depressurised standby function

and therefore

- greater service life
- lower maintenance costs and
- fail save operation



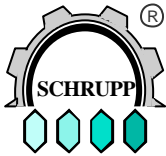

GAS DRYER TYPE GTR

www.hl-hydraulik.de

Functional Description

The drier station consists of the gas drier, fine filter, pressure relief valve, pressure holding and check valves and the electrical control unit.

These components are mounted on a frame, pipe connected and wired ready for operation. The gas drier consists of two reservoirs filled with highly porous hydrostatic materials (adsorbents), into which damp compressed air and dried depressurized air are alternately admitted for the regeneration phase.

The damp air coming from the compressor passes through the fine filter (6) and the energized open 3/2-way valve DN 6 (1.1), which voltage is being passed, and reaches the reservoir (1.5).

The adsorbent in reservoir (1.5) removes the moisture from the damp compressed air as it passes through this reservoir. The now dry air passes via the check valve (1.9), pressure holding valve (4) and check valve (5.1) to the storage vessel or to the consumer. A small portion of this dried compressed air is depressurized in the throttle valve (1.11) and flows through the check valve (1.8) to the reservoir (1.6). This dried air absorbs the water from the damp adsorbents and passes via the 3/2-way valve (1.2) into the atmosphere, thus regenerating the adsorbents.

The inlet and outlet of the adsorbent reservoirs are each fitted with a sintered metal disk. These disks filter the water and oil particles out of the incoming damp air and any particles of adsorbate material from the outgoing air.

Since drying and regeneration are performed in a counter-flow procedure, any residues are removed from the sintered metal disks at each reversal of the direction of flow.

After the preset time interval (e.g. 10 minutes), the two 3/2-way valves (1.1 and 1.2) are automatically reversed via a timer switch.

The procedure described above is now repeated but with the reservoirs "reversed".

The drying procedure is connected to the operation of the compressor. When the compressor is switched off, both 3/2-way valves (1.1 and 1.2) are closed (off position).

The pressure relief valve (7) opens and the condensate in the fine filter (6) is discharged.

When the compressor is restarted, the drying procedure is continued where it was interrupted.

Using this method, extremely low pressure dew points can be achieved (depending on the operating pressure, down to -50°C and lower measured at the drier outlet).

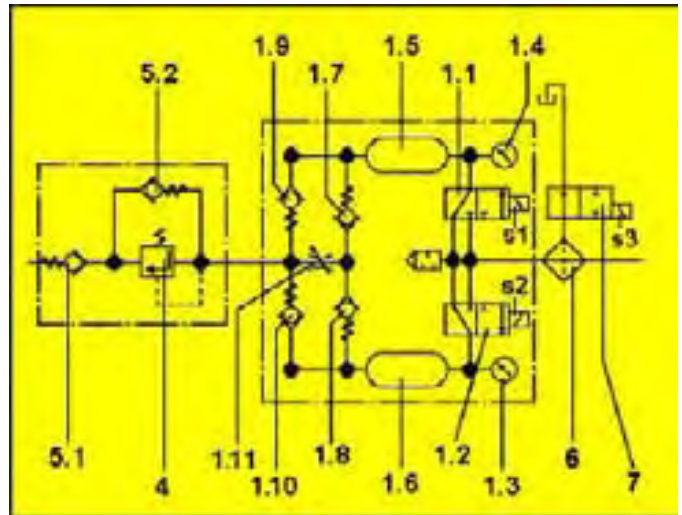

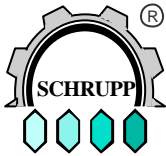

**GAS DRYER
TYPE GTR**

www.hl-hydraulik.de

The drier station consists of:

- | | | |
|---|---|----------------------------|
| 1 | 1 Gas drier | Type GT 1000/250 |
| | Max. operating pressure | 45 bar |
| | Flow rate | 1000 l/min |
| | Regeneration air | 5-10% of compressor rating |
| | Control voltage | AC or DC |
| 2 | 1 Electrical control unit with time lag switching-off | Type 168 332 |
| 3 | 1 Silencer | Type 162 987 |
| 4 | 1 Pressure holding valve Set to | Type V 501 b (max. 45 bar) |
| 5 | 2 Check valves DN 15, PN 45 | Type Ap 9308 |
| 6 | 1 Fine filter Capacity | Type 450 688 0.65 liter |
| 7 | 1 2/2-way valve DN 6, PN 250 Voltage 220 V, 50 Hz | Type 500 004 |
| 8 | 1 Mounting frame | Type 169 286 |

Installation, connection, bolts, cables, etc.

All above components assembled, piped connected, wired and tested

Product No. 169 300

The drier station consists of:

- | | | |
|---|---|----------------------------|
| 1 | 1 Gas drier | Type GT 1000/250 |
| | Max. operating pressure | 250 bar |
| | Flow rate | 1000 l/min |
| | Regeneration air | 5-10% of compressor rating |
| | Control voltage | AC or DC |
| 2 | 1 Electrical control unit with time lag switching-off | Type 168 332 |
| 3 | 1 Silencer | Type 162 987 |
| 4 | 1 Pressure holding valve Set to | (max. 250 bar) |
| 5 | 2 Check valves DN 8, PN 250 | Type 450 050 |
| 6 | 1 Fine filter Capacity | Type 450 688 0.65 liter |
| 7 | 1 2/2-way valve DN 6, PN 250 Voltage 220 V, 50 Hz | Type 500 004 |
| 8 | 1 Mounting frame | Type 450 738 |

Installation, connection, bolts, cables, etc.

All above components assembled, piped connected, wired and tested

Product No. 169 460

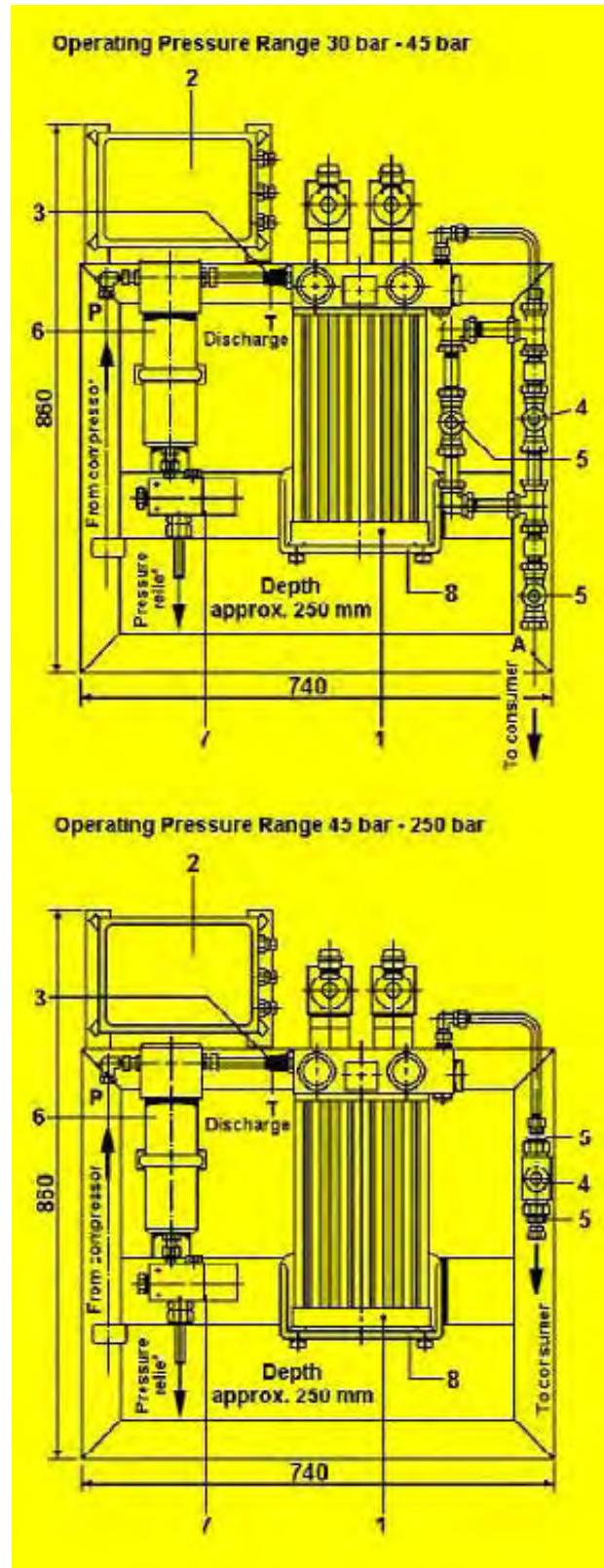



**GAS DRYER
TYPE GTR**

www.hl-hydraulik.de

